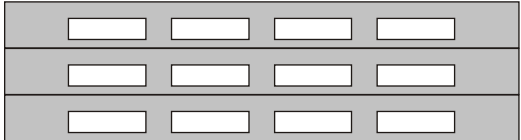
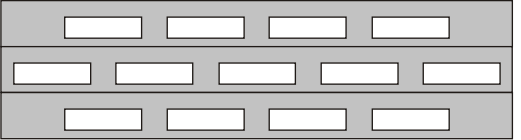
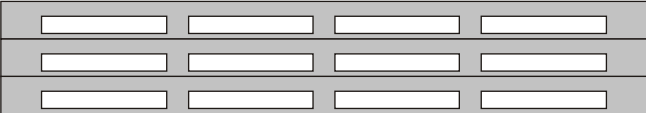
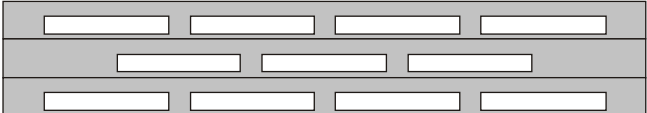

ALUMINIUM ROLLER SHUTTERS

Metal Services Ltd has established itself as a quality supplier of aluminium roller shutter sections & related products. We carry a wide range of lengths ex-stock of both light & heavy duty lath for optimum yield, which are then cut to size & punched if required. Lath sections can be punched to accept our standard endlocks.

AVAILABLE PUNCH STYLES & SIZES

	MS124/126 SINGLE PUNCH IN LINE & BRICKBOND 150mm x 41mm	
---	--	--

MS124/126 DOUBLE PUNCH IN LINE & BRICKBOND 290mm x 41mm Punch Size 25mm Gap = 40% Open Area	
	

Also Available:-
MS129 Single Punch size = 100 x 25 mm
In addition to our standard punch patterns we are also able to offer custom made shapes, such as company logos.

Approximate weight per square metre

	SOLID	PUNCHED	PUNCHED & GLAZED	OPEN AREA %
MS129	7 KGS	4.7 KGS	N / A	33%
MS126	7 KGS	5.1 KGS	6.5 KGS	27%
MS124	10 KGS	7.3 KGS	8.7 KGS	27%
MS140	10 KGS	N / A	N / A	N / A

In addition to the aluminium sections we also offer from stock:

- Guides and bottom rails* - For light and heavy duty
- End locks* - 50 mm, 90 mm Single lath & 90mm Double Skin Security Endlock
- Polycarbonate glazing strips* - 1.5mm thick available in 2mtr & 4mtr lengths
- Noise reduction strip* - to suit MS127 HD guide
- Weather seal* - to suit Ms125 HD bottom rail
- Standard extrusion* - angles, tubes, flats, channels, bar etc
- Aluminium sheet* - mill finish, patterned and anodised

Fabrication facilities are available in house and painting to standard RAL powder coated colours is offered.

TEL: 0191 4140944 FAX: 0191 4140914

Website: www.metalservices.co.uk email: sales@metalservices.co.uk